

FICHE D'HOMOLOGATION HOMOLOGATION FORM



COMMISSION INTERNATIONALE DE KARTING - FIA



MOTEUR / ENGINE KF1

Le présent document intègre les Errata et comprend en annexe les différentes VO et ET applicables.		<i>This document integrates Errata and the various applicable VO's and ETs are appended.</i>
Constructeur	<i>Manufacturer</i>	TM RACING S.p.A
Marque	<i>Make</i>	TM RACING
Modèle	<i>Model</i>	MF1
Durée de l'homologation	<i>Validity of the homologation</i>	9 ans / 9 years
Nombre de pages	<i>Number of pages</i>	12 + 4

La présente Fiche d'Homologation reproduit descriptions, illustrations et dimensions du moteur au moment de l'homologation par la CIK-FIA. La hauteur du moteur complet sur les photos doit être de 7 cm minimum.

This Homologation Form reproduces descriptions, illustrations and dimensions of the engine at the time the CIK-FIA conducted the homologation. The height of the complete engine on all photographs must be as a minimum 7 cm.



PHOTO DU MOTEUR CÔTÉ PIGNON
PHOTO OF DRIVE SIDE OF ENGINE

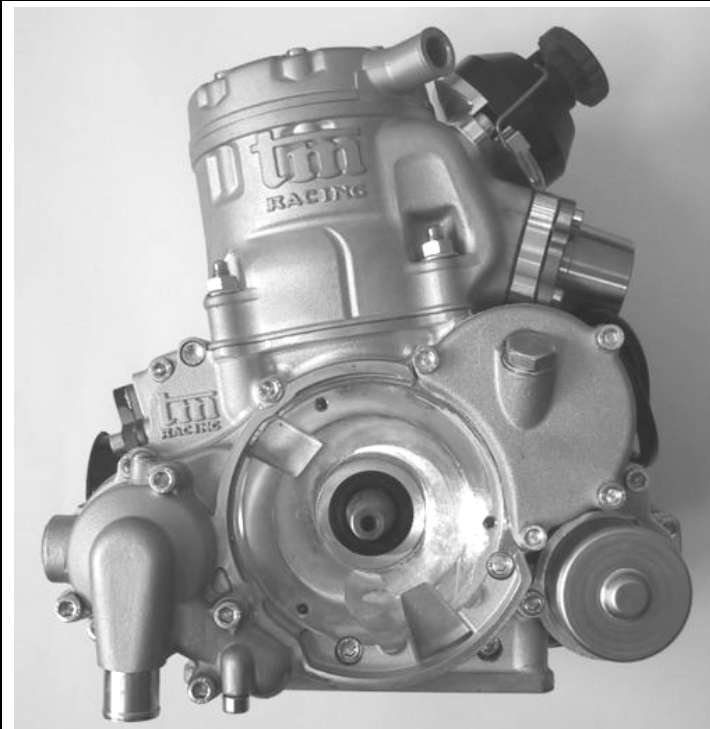

PHOTO DU MOTEUR CÔTÉ OPPOSÉ
PHOTO OF OPPOSITE SIDE OF ENGINE

Signature et tampon de l'ASN
Signature and stamp of the ASN

Signature et tampon de la CIK-FIA
Signature and stamp of the CIK-FIA



Glauco

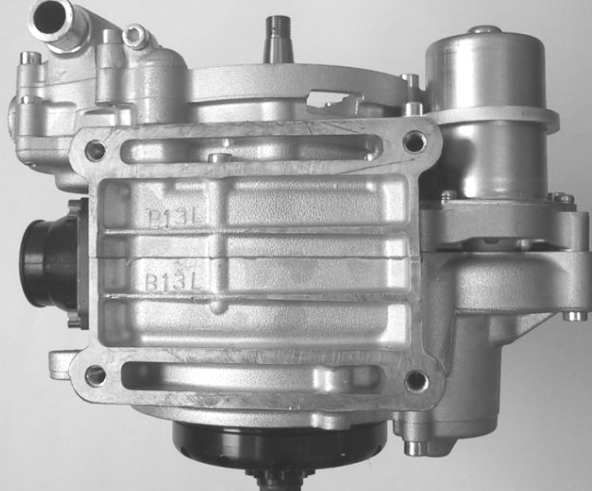
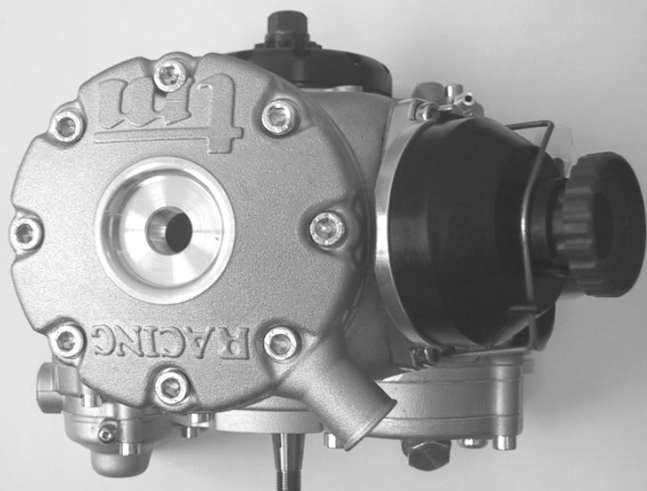

[Signature]

PHOTOS DU MOTEUR COMPLET**PHOTOS OF THE COMPLETE ENGINE**PHOTO DE L'ARRIÈRE
DU MOTEUR*PHOTO OF THE REAR
OF THE ENGINE*PHOTO DE L'AVANT
DU MOTEUR*PHOTO OF THE
FRONT OF THE
ENGINE*PHOTO DU MOTEUR
VU DU HAUT*PHOTO OF THE
ENGINE TAKEN FROM
ABOVE*PHOTO DU MOTEUR
VU DU DESSOUS*PHOTO OF THE
ENGINE TAKEN FROM
BELOW*

INFORMATIONS TECHNIQUES**TECHNICAL INFORMATION**

A	CARACTÉRISTIQUES	A	CHARACTERISTICS
			Tolérances / remarques Tolerances & remarks
	Cylindre		Cylinder
	Volume du cylindre	Volume of cylinder	<u>124.36 cm³</u> <u>125cm ³
	Alésage d'origine	Original bore	<u>53.95 mm</u> --
	Alésage théorique maximum	Theoretical maximum bore	<u>54.08 mm</u> --
	Course d'origine	Original Stroke	<u>54.40 mm</u> --
	Nombre de canaux de transfert, cylindre/carter	Number of transfer ducts, cylinder/sump	<u>5 / 3</u> --
	Nombre de lumières / canaux d'échappement	Number of exhaust ports / ducts	<u>3</u> --
	Volume de la chambre de combustion	Volume of the combustion chamber	<u>9.0 cm³</u> Mini
	Vilebrequin		Crankshaft
	Nombre de paliers	Number of bearings	<u>2</u> --
	Diamètre des paliers	Diameter of bearings	<u>28</u> ±0.1mm
	Poids minimum du vilebrequin	Minimum weight of crankshaft	<u>2104 g</u> minimum
	Ensemble des pièces représentées sur la photo page 7	All parts represented on page 7 photo	
	Arbre d'équilibrage		Balance shaft
	Poids minimum de l'arbre d'équilibrage	Minimum weight of balance shaft	<u>329 g</u> minimum
	Pourcentage d'Equilibrage	Percentage of balancing	<u>25%</u> minimum
	Bielle		Connecting rod
	Longueur (entre-axe) de la bielle	Connecting rod centreline	<u>104 mm</u> ±0.2mm
	Diamètre de la tête de bielle	Diameter of big end	<u>26 mm</u> ±0.05mm
	Diamètre du pied de bielle	Diameter of small end	<u>19 mm</u> ±0.05mm
	Poids minimum de la bielle	Min. weight of the connecting rod	<u>108 g</u> minimum

Piston	Piston		
Nombre de ségments du piston	<i>Number of piston rings</i>	1	
Poids minimum du piston nu	<i>Min. weight of the bare piston</i>	108 g	minimum
Axe du piston	Gudgeon pin		
Poids minimum	<i>Minimum weight</i>	24 g	Minimum
Embrayage	Clutch		
Poids minimum	<i>Minimum weight</i>	890 g	minimum
De l'ensemble des pièces représentées dans le dessin technique page 14 de la Fiche d'Homologation KF4	<i>Of all the parts represented on the page 14 technical drawing from KF4 Homologation Form</i>		

C	MATÉRIAU	C	MATERIAL
	Culasse		<i>Cylinder head</i>
	Cylindre		<i>Cylinder</i>
	Paroi du cylindre		<i>Cylinder wall</i>
	Carter		<i>Sump</i>
	Vilebrequin		<i>Crankshaft</i>
	Bielle		<i>Connecting rod</i>
	Piston		<i>Piston</i>
			ALUMINIUM ALLOY
			ALUMINIUM ALLOY
			CAST IRON
			ALUMINIUM ALLOY
			STEEL
			STEEL
			ALUMINIUM ALLOY

D	PHOTOS, DESSINS & GRAPHIQUES	D	PHOTOS, DRAWINGS & GRAPHS
---	------------------------------	---	---------------------------

D.1 CYLINDRE / CYLINDER UNIT

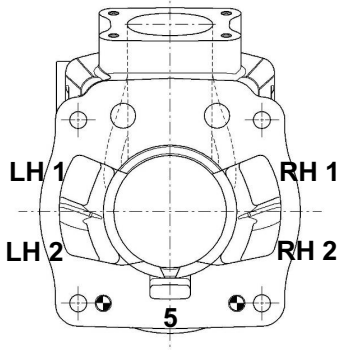
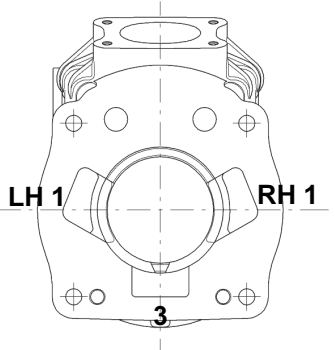
VOLUME DES CANAUX DE TRANSFERT		TRANSFER DUCTS VOLUME	
Position des transferts sur cylindre 5 transferts <i>Transfer position on 5-transfer cylinder</i>	Position des transferts sur cylindre 3 transferts <i>Transfer position on 3-transfer cylinder</i>	TRANSFERT N° <i>TRANSFER No.</i>	VOLUME <i>en cm³ / in cc</i> +/- 5 %
		Transfert N° 1 LH <i>Transfer No. 1 LH</i>	32.4
		Transfert N° 2 LH <i>Transfer No. 2 LH</i>	
		Transfert N° 3 ou 5 <i>Transfer No. 3 or 5</i>	4.7 +/- 8 %
		Transfert N° 2 RH <i>Transfer No. 2 HR</i>	32.4
		Transfert N° 1 RH <i>Transfer No. 1 HR</i>	

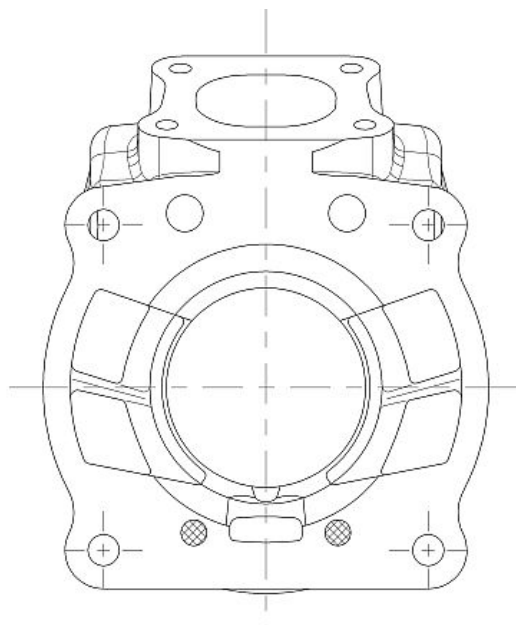

DESSIN DU PIED DU CYLINDRE sans dimensions

DRAWING OF THE CYLINDER BASE without dimensions

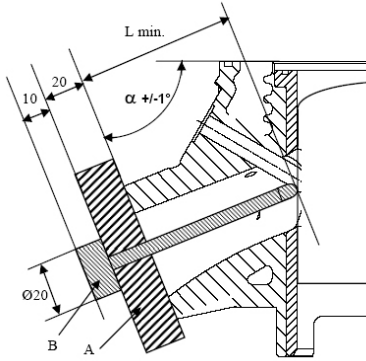
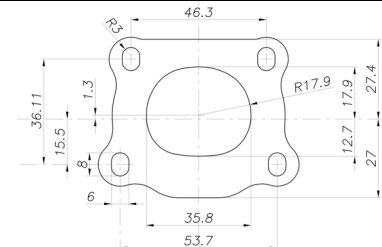
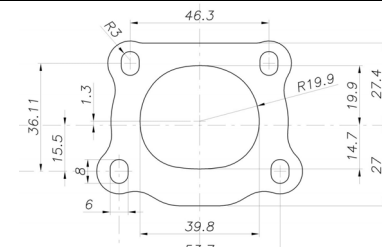

Uniquement contrôlé avec gabarits / *Control with templates only*

... Section D.1

LONGUEUR DU CANAL D'ÉCHAPPEMENT		EXHAUST DUCT LENGTH	
ANGLE α en / in °		L minimum en / in mm	
65 +/-1°		50.87 mm	
La mesure L min. sera le résultat de la valeur relevée sur le moteur de référence moins 5 mm. The L min. dimension will be the result of the value taken on the reference engine minus 5 mm.			
Dessin Technique N°13		Technical Drawing No.13	
			
<ul style="list-style-type: none"> A : Guide-centreur se centrant par rapport au canal d'échappement par les vis de fixation du collecteur d'échappement, ayant une épaisseur totale de 20 +/- 0,05 mm et étant percé en son centre d'un trou de diamètre 5 mm, alésé H7. A: Centring guide centred in relation to the exhaust duct by the exhaust manifold fixation screws, with a total thickness of 20 +/- 0.05 mm and being drilled in its centre by a hole with a 5 mm diameter, H7 bore. B : Jauge de contrôle composée d'une tige de diamètre 5g6 ayant à son extrémité un rayon de 2,5 mm et d'une longueur = L min + 20+10. B: Control gauge composed of a shaft with a 5g6 diameter having a 2.5 mm radius at its end and a length = L min + 20+10. 			
PROFIL INTERIEUR DE SORTIE DU CANAL D'ÉCHAPPEMENT		INTERNAL PROFILE OF THE EXHAUST DUCT	
Gabarits des dimensions intérieures du canal d'échappement : plan de joint du collecteur. Templates of the internal dimensions of the exhaust duct: gasket plane of the manifold.			
DESSIN VUE DE FACE – avec dimensions / FRONT VIEW DRAWING – with dimensions			
Gabarit minimum / Minimum template		Gabarit maximum / Maximum template	
			
<ul style="list-style-type: none"> Gabarit maximum : profil intérieur du plan de joint du collecteur du cylindre d'origine plus 1 mm Maximum template: internal profile of the gasket plane of the manifold of the original cylinder plus 1 mm Gabarit minimum : profil intérieur du plan de joint du collecteur du cylindre d'origine moins 1 mm Minimum template: internal profile of the gasket plane of the manifold of the original cylinder minus 1 mm Épaisseur / Thickness: 5 +/- 0,05 mm 		Dessin Technique N°13 bis  Technical Drawing No.13 bis	

D.2 BIELLE, CARTERS, VILEBREQUIN & PISTON / CONROD, CRANKCASE, CRANKSHAFT & PISTON

PHOTO DE L'EMBIELLAGE
PHOTO OF THE CRANKSHAFT & CONROD

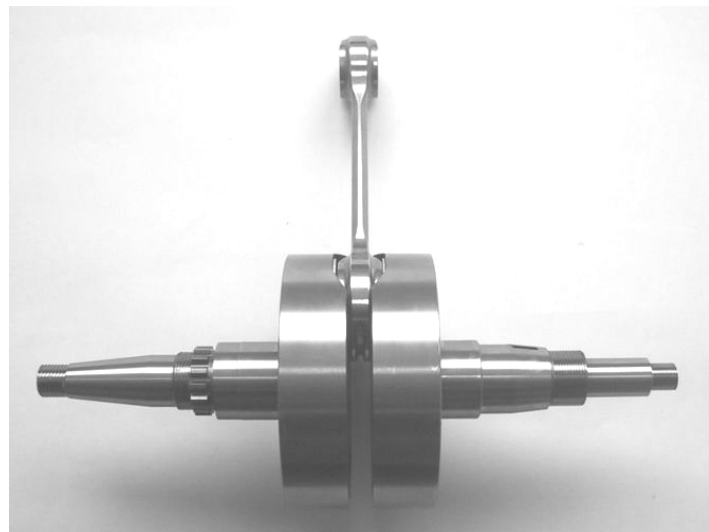
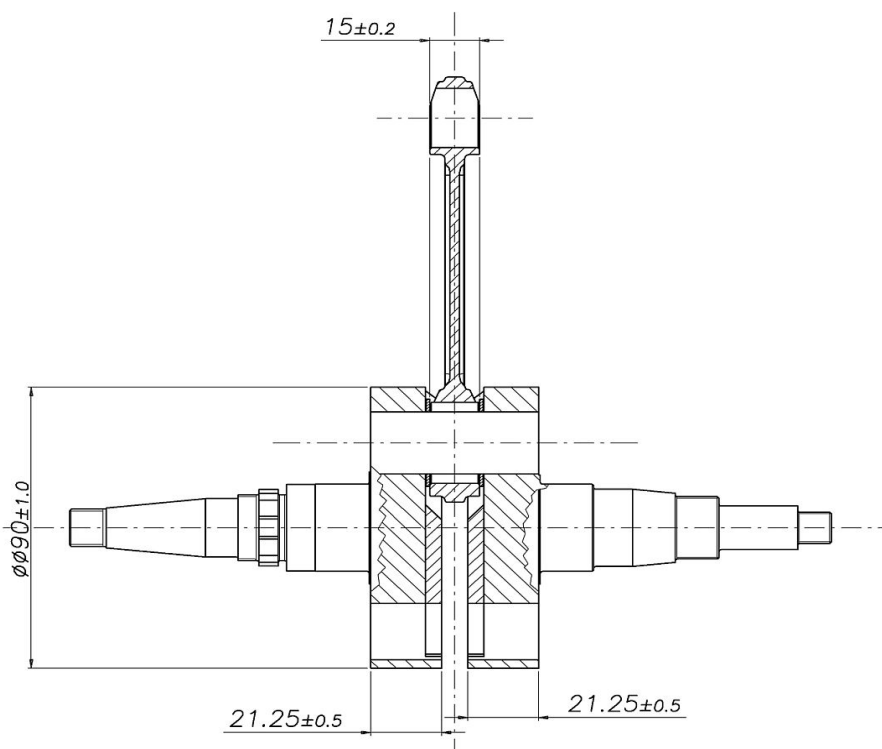

PHOTO DE LA BIELLE
PHOTO OF THE CONROD



DESSIN DE L'ENSEMBLE VILEBREQUIN -
BIELLE (DIMENSIONS avec tolérances, largeurs
pied & tête de bielle, largeur & diamètre des
contrepoids)

DRAWING OF THE CRANKSHAFT - CON ROD
UNIT (DIMENSIONS incl. tolerances, big & small
ends thickness, crank mass thickness &
diameter)

**01/01/ER**

D.3 L'ARBRE D'ÉQUILIBRAGE, DE LA POMPE À EAU / BALANCE SHAFT & WATER PUMP

PHOTO DE L'ARBRE D'ÉQUILIBRAGE
PHOTO OF THE BALANCE SHAFT



DESSIN DE L'ARBRE D'ÉQUILIBRAGE
(DIMENSIONS avec tolérances)

DRAWING OF THE BALANCE SHAFT
(DIMENSIONS incl. tolerances)

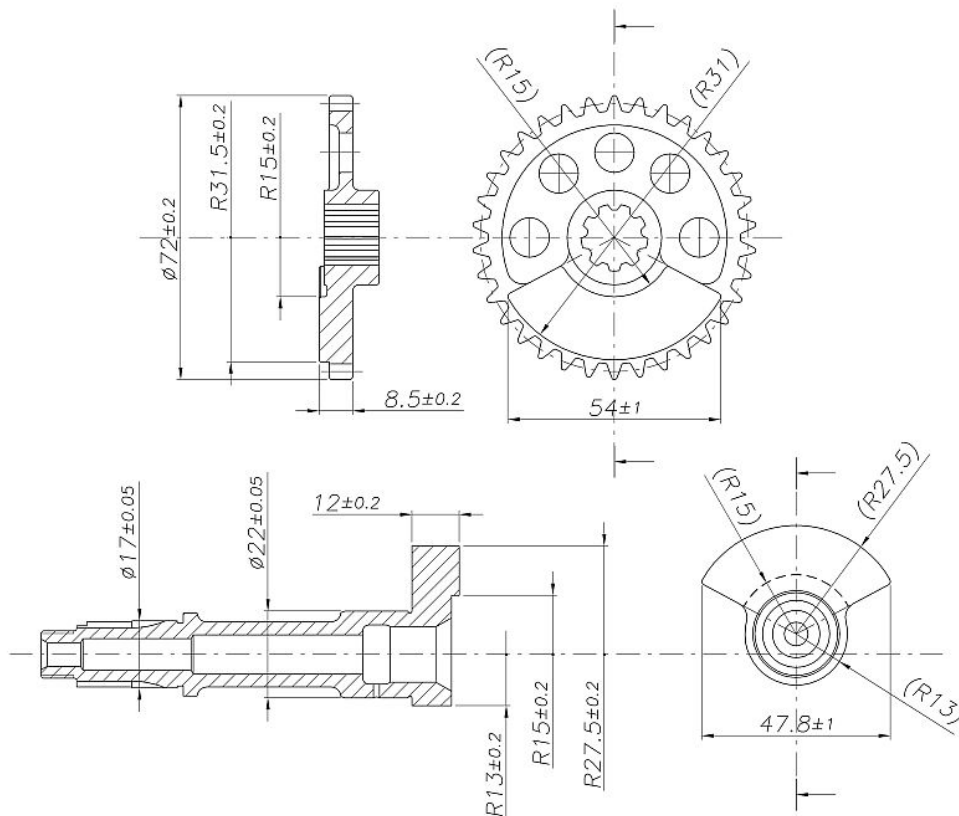

D.4 CLAPETS & EMBRAYAGE / REED VALVE & CLUTCH

DESSIN DE LA BOÎTE À CLAPETS
(DIMENSIONS avec **tolérances**)

DRAWING OF THE REED VALVE
(DIMENSIONS incl. **tolerances**)

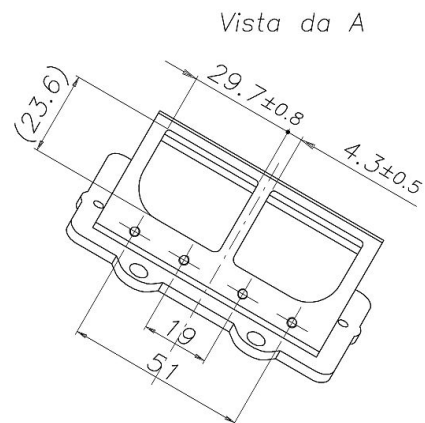
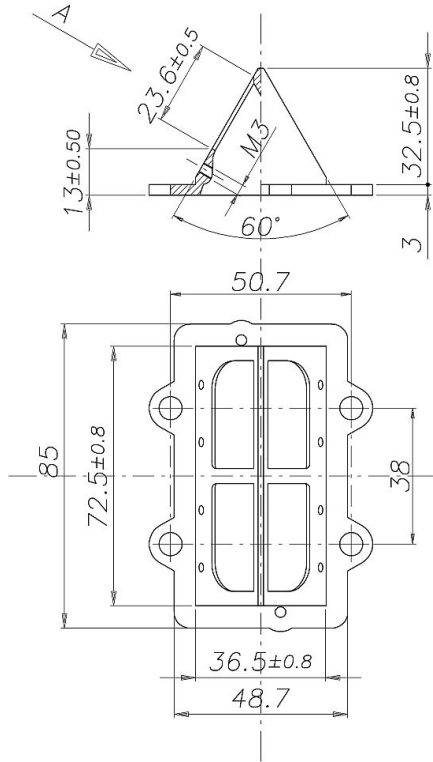
**01/01/ER**

D.5 SYSTEME D'ÉCHAPPEMENT / EXHAUST SYSTEM

PHOTO DE L'ÉCHAPPEMENT

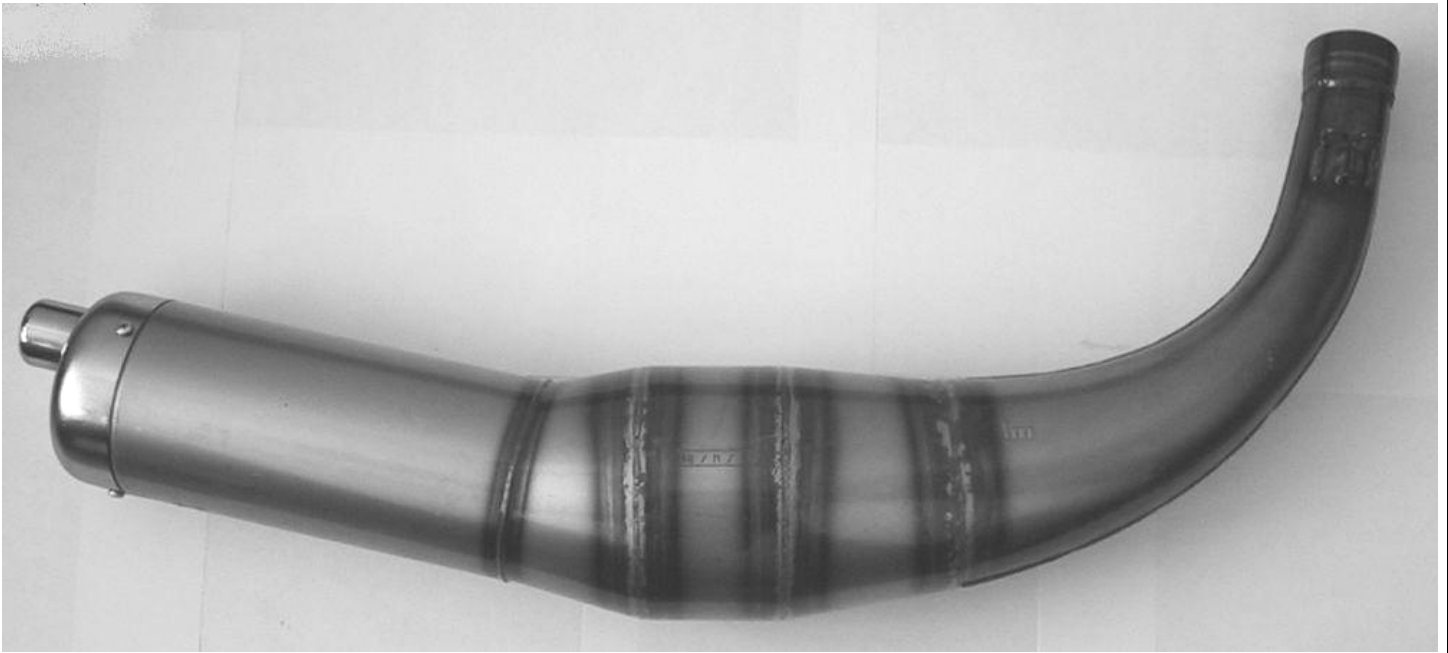
PHOTO OF THE EXHAUST

... Section D.5

DESCRIPTIONS TECHNIQUES DE L'ÉCHAPPEMENT (Art. 8.9.3 du RH)		TECHNICAL DESCRIPTIONS OF THE EXHAUST (Art. 8.9.3 of HR)	
Poids en g	Weight in g	2007	Minimum
Volume in cm ³	Volume in cc	5200	+/- 5 %

DESSIN TECHNIQUE	TECHNICAL DRAWING
Il doit contenir toutes les informations permettant de construire cet échappement.	It must include all the information necessary to build this exhaust.

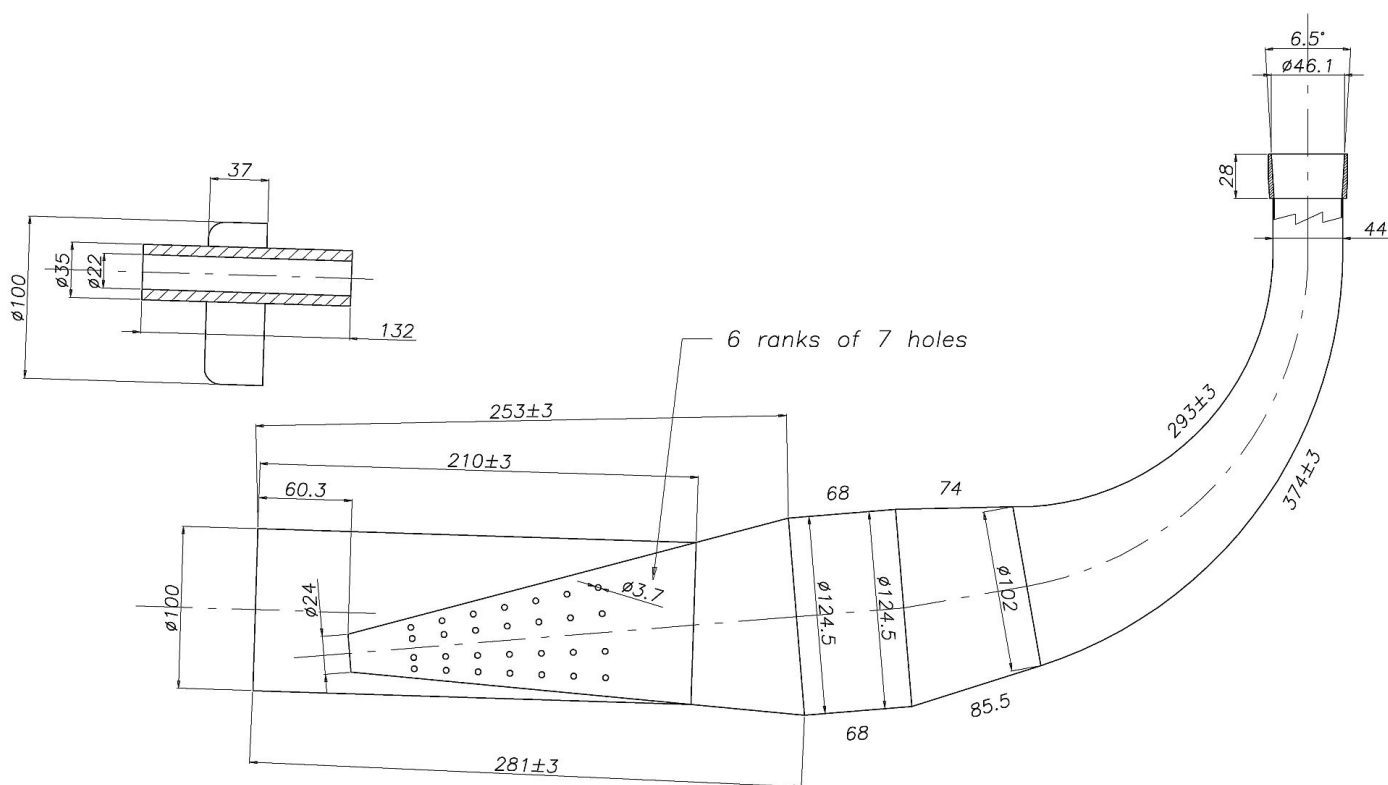
**01/01/ER**

... Section D.5

DESSIN EXPLODÉ ET DÉNOMINATION DES
ELEMENTS DE LA POWER VALVE

EXPLODED DRAWING AND DESIGNATION OF
THE POWER VALVE COMPONENTS

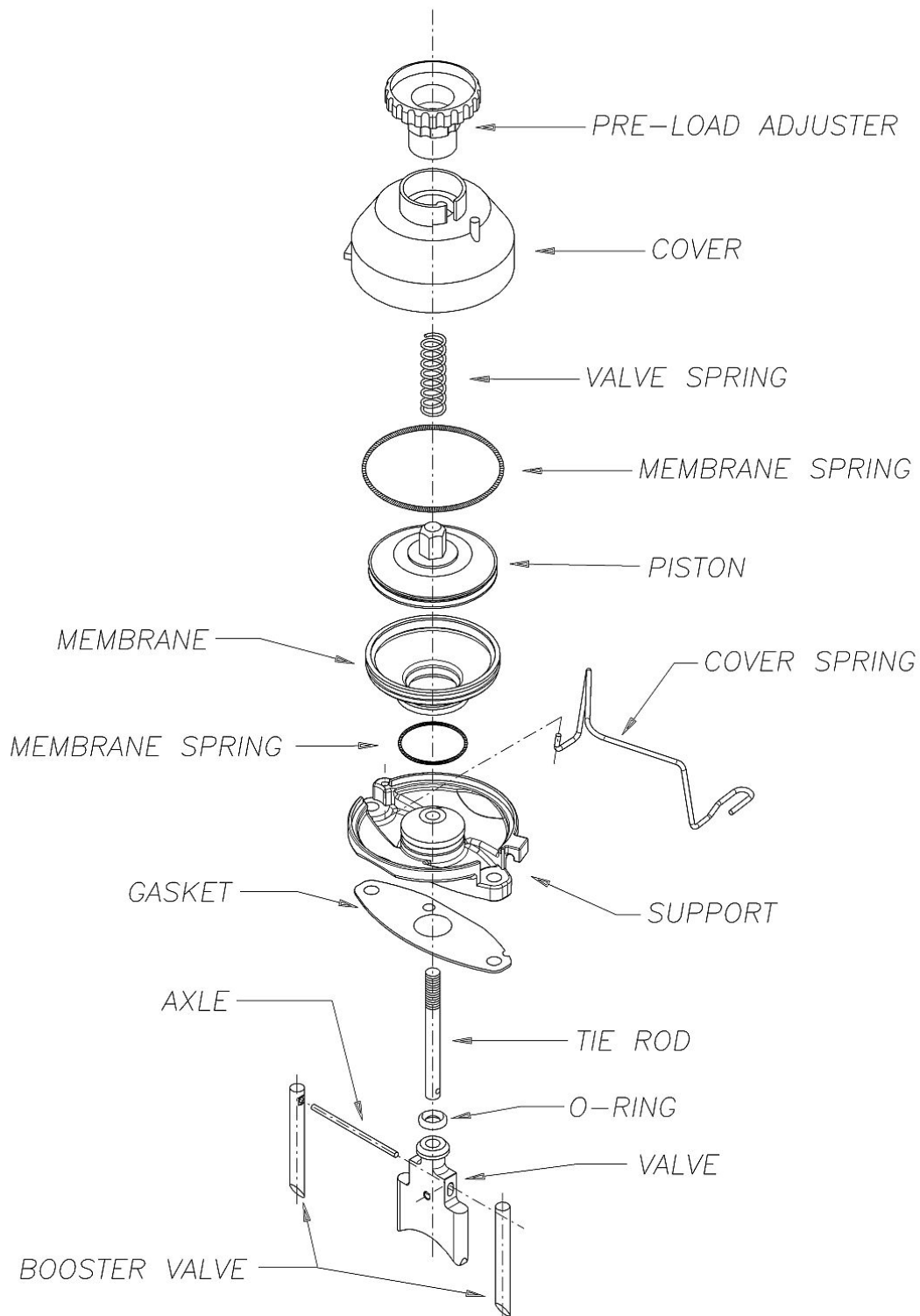

VARIANTES OPTIONS À LA FICHE
D'HOMOLOGATION
OPTION VARIANTS TO THE
HOMOLOGATION FORM

Homologation N°

40/M/15
02/01/VO



COMMISSION INTERNATIONALE
DE KARTING - FIA



Constructeur : TM RACING S.p.A
Manufacturer:

Adresse : Via Fano 6 – 61100.- Pesaro.-Italy
Address:

Marque : TM RACING Modèle : MF1
Make: Model:

Catégorie : KF1, KF2, KF3, KF4 nombre des pages : 1 +3
Category: Number of pages:

La Variante Option est prononcée à compter du : 01 janvier 2008
The Option Variant comes into effect on: (à remplir par la CIK-FIA)
(to be filled in by the CIK-FIA)

Description : au moins dans une des deux langues officielles (français-anglais)
in at least one of the two official languages (French/English)

- **Crankshaft**
- Clutch
- Exhaust manifold unit
- Water pump cover
- Reed valve
- **Power valve component**
- Starting unit and its housing
- Piston

JOINDRE : Dessin ou photo des pièces nouvelles selon Fiche d'Homologation
ATTACH: Drawing or photograph of the new parts on the Homologation Form

Timbre et signature de l'ASN
ASN's stamp and signature:

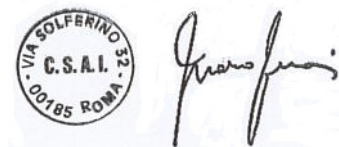

Timbre et signature de la CIK-FIA
CIK-FIA's stamp and signature:



Date : 22/11/2007

Date : 19/12/2007

A	CARACTÉRISTIQUES	A	CHARACTERISTICS
---	------------------	---	-----------------

			Tolérances / remarques Tolerances & remarks
Vilebrequin	Crankshaft		
Poids minimum du vilebrequin	<i>Minimum weight of crankshaft</i>	1901 g	minimum
Embrayage	Clutch		
Poids minimum	<i>Minimum weight</i>	800 g	minimum

D.2 BIELLE, CARTERS, VILEBREQUIN & PISTON / CONROD, CRANKCASE, CRANKSHAFT & PISTON

PHOTO DE L'EMBIELLAGE
PHOTO OF THE CRANKSHAFT & CONROD

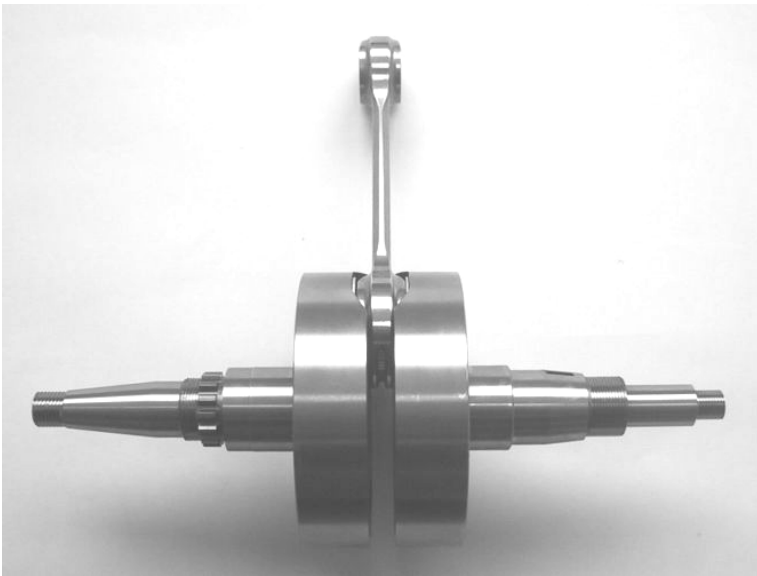

... Section D.2

DESSIN DE L'ENSEMBLE VILEBREQUIN -
BIELLE (DIMENSIONS avec tolérances, largeurs
ped & tête de bielle, largeur & diamètre des
contrepoids)

*DRAWING OF THE CRANKSHAFT - CON ROD
UNIT (DIMENSIONS incl. tolerances, big & small
ends thickness, crank mass thickness &
diameter)*

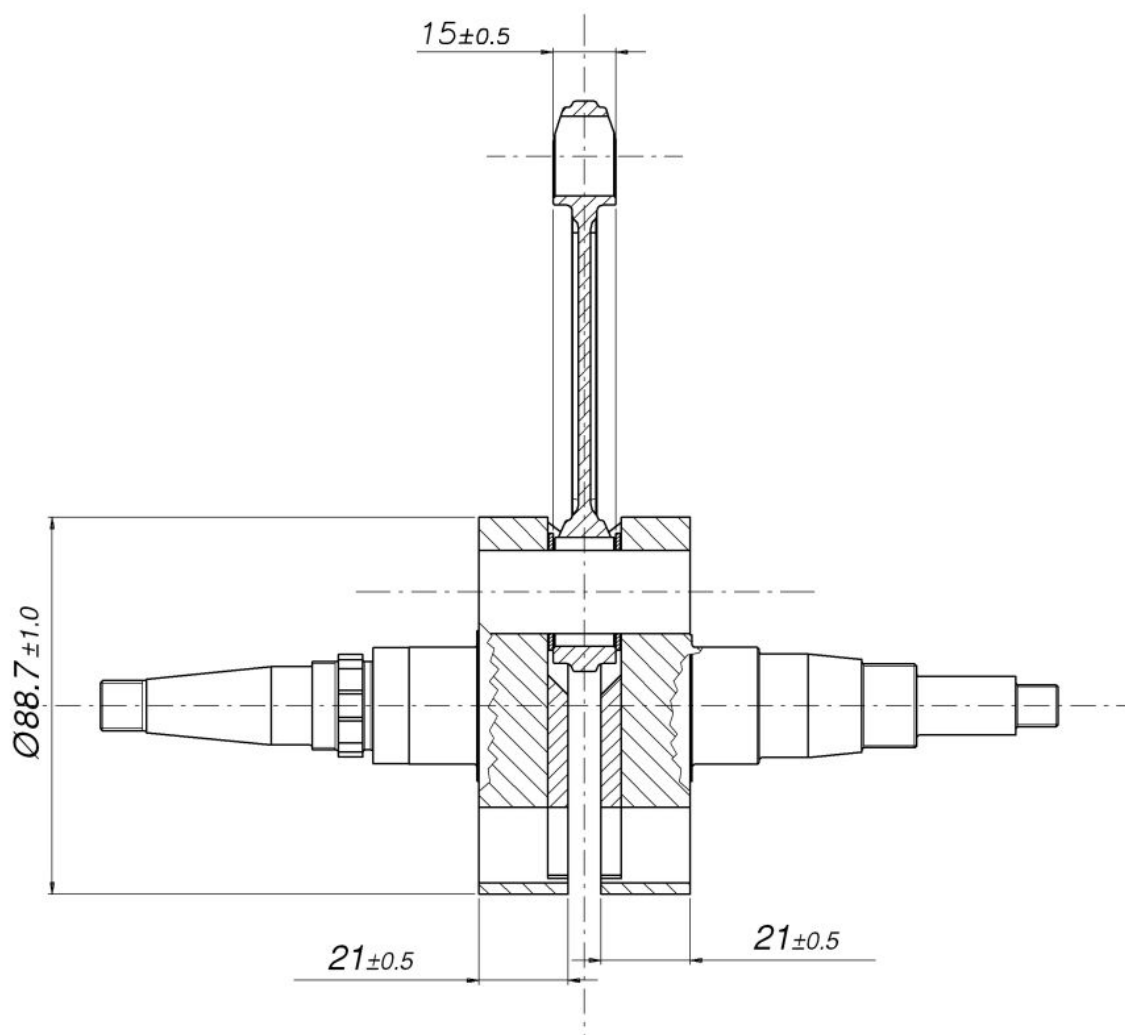

D.5 SYSTEME D'ÉCHAPPEMENT / EXHAUST SYSTEM

DESSIN EXPLODÉ ET DÉNOMINATION DES
ELEMENTS DE LA POWER VALVE

EXPLODED DRAWING AND DESIGNATION OF
THE POWER VALVE COMPONENTS

