

FICHE D'HOMOLOGATION HOMOLOGATION FORM



COMMISSION INTERNATIONALE DE KARTING - FIA



MOTEUR / ENGINE SUPER ICC / ICC

Constructeur	<i>Manufacturer</i>	TM RACING – ITALY
Marque	<i>Make</i>	TM RACING
Modèle	<i>Model</i>	K9 B
Type d'admission	<i>Inlet type</i>	REED VALVE
Durée de l'homologation	<i>Validity of the homologation</i>	6 ans / 6 years
Nombre de pages	<i>Number of pages</i>	9

La présente Fiche d'Homologation reproduit descriptions, illustrations et dimensions du moteur au moment de l'homologation CIK-FIA. Le Constructeur a la possibilité de les modifier seulement dans les limites fixées par le Règlement CIK-FIA en vigueur. La hauteur du moteur complet sur les photos doit être de 7cm minimum.

This Homologation Form reproduces descriptions, illustrations and dimensions of the engine at the moment of the CIK-FIA homologation. The Manufacturer may modify them, but only within the limits fixed by the CIK-FIA Regulations in force. The height of complete engines on all photos must be minimum 7cm.



PHOTO DU MOTEUR CÔTÉ PIGNON
PHOTO OF DRIVE SIDE OF ENGINE



PHOTO DU MOTEUR CÔTÉ OPPOSÉ
PHOTO OF OPPOSITE SIDE OF ENGINE

Signature et tampon de l'ASN
Signature and stamp of the ASN

Signature et tampon de la CIK-FIA
Signature and stamp of the CIK-FIA



Glauco



[Signature]

INFORMATIONS TECHNIQUES		TECHNICAL INFORMATION	
A	CARACTÉRISTIQUES	A	CHARACTERISTICS
			Tolérances
Volume du cylindre	<i>Volume of cylinder</i>	124.66 CM3	< 125cm³
Alésage d'origine	<i>Original Bore</i>	54.00 MM	
Alésage théorique maximum	<i>Theoretical maximum bore</i>	54.07 MM	
Course	<i>Stroke</i>	54.43 MM	
Système de refroidissement	<i>Cooling system</i>	WATER	
Nombre de systèmes de carburation	<i>Number of carburation systems</i>	1 CARBURATOR	
Nombre de canaux de transfert, cylindre/carter	<i>Number of transfer ducts, cylinder/sump</i>	5	
Nombre de lumières / canaux d'échappement	<i>Number of exhaust ports / ducts</i>	3	
Forme de la chambre de combustion	<i>Shape of the combustion chamber</i>	SPHERIC WITH VARIABLE RADIUS+SQUISH	
Matériau de la paroi du cylindre	<i>Cylinder wall material</i>	ALLUMINIUM+NICASIL	
Longueur (entre-axe) de la bielle	<i>Length between the axes of the connecting rod</i>	109.8	±0.1mm
Volume de la chambre de combustion	<i>Volume of combustion chamber</i>	13 CC	Minimum
Modifications autorisées selon le Règlement Technique. Seules les dimensions et cotes qui ne peuvent pas être modifiées doivent figurer sur la Fiche d'Homologation. <i>Modification allowed according to the Technical Regulations.</i> <i>Only the dimensions and readings which may not be changed must be mentioned on the Homologation Form.</i>			

B	ANGLES D'OUVERTURE	B	OPENING ANGLES
De l'échappement	<i>Exhaust</i>	199°	Max

C	MATÉRIAU	C	MATERIAL
Cylindre	<i>Cylinder</i>		ALLUMINIUM+NICASIL
Culasse	<i>Cylinder head</i>		ALLUMINIUM
Carter	<i>Sump</i>		ALLUMINIUM+STEEL'S BUSH
Bielle	<i>Connecting rod</i>		STEEL

DESSIN DU DÉVELOPPEMENT DU CYLINDRE

DRAWING OF THE CYLINDER DEVELOPMENT

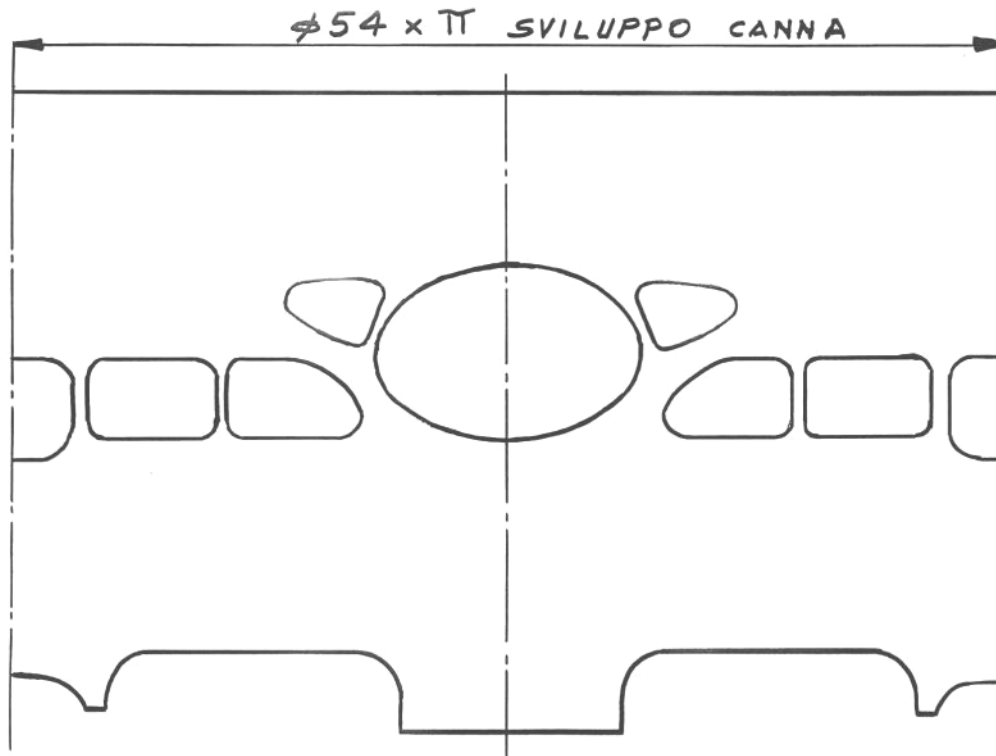
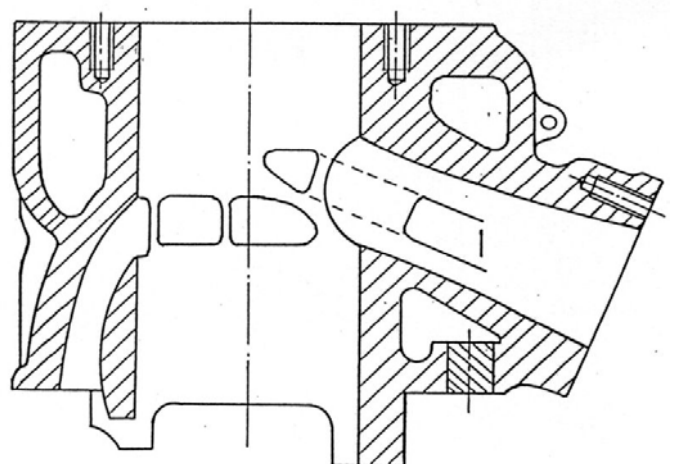
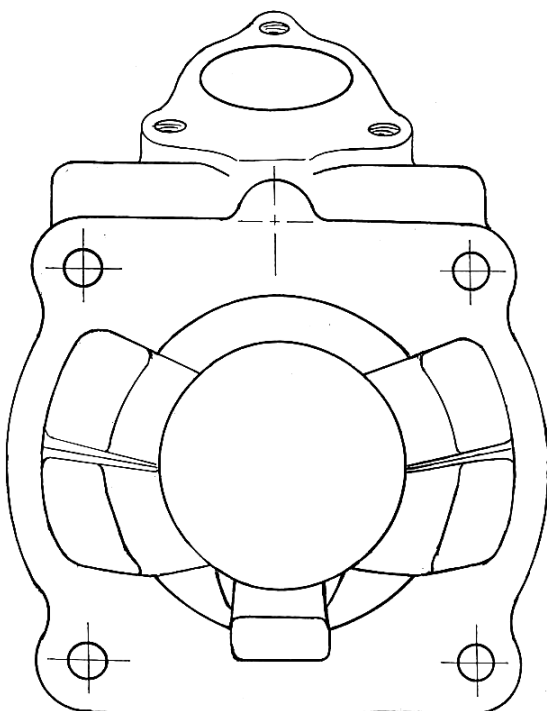
DESSIN DU PIED DU
CYLINDREDRAWING OF THE
CYLINDER BASEVUE EN SECTION DU
CYLINDRESECTION VIEW OF
CYLINDER

DESSIN DE LA CULASSE ET DE LA CHAMBRE
DE COMBUSTION

*DRAWING OF THE CYLINDER HEAD AND OF
THE COMBUSTION CHAMBER*

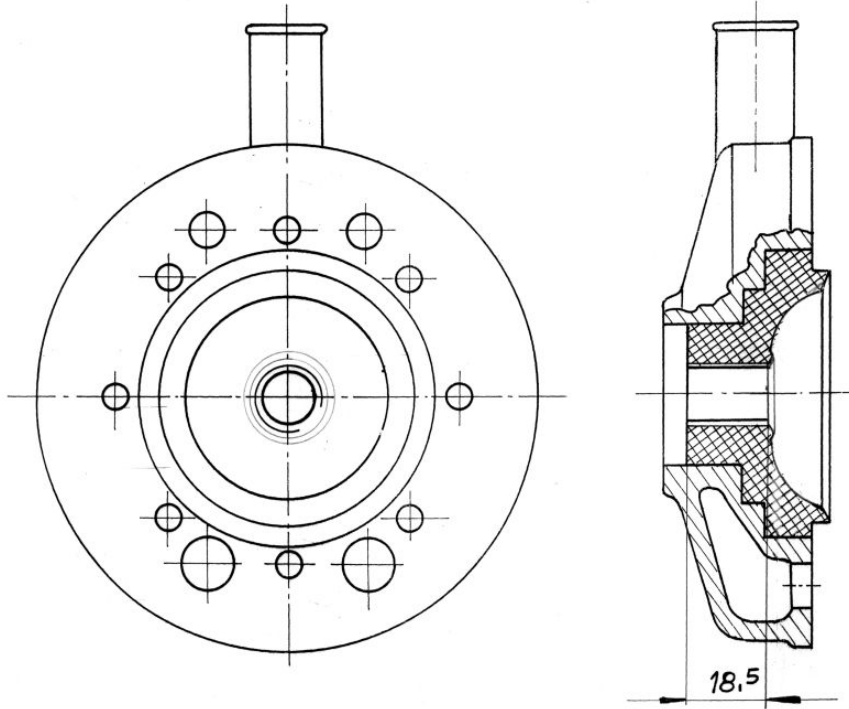

DESSIN DU
VILEBREQUIN

*DRAWING OF THE
CRANKSHAFT*

DESSIN INTÉRIEUR
DU CARTER

*DRAWING OF THE
INSIDE OF SUMP*

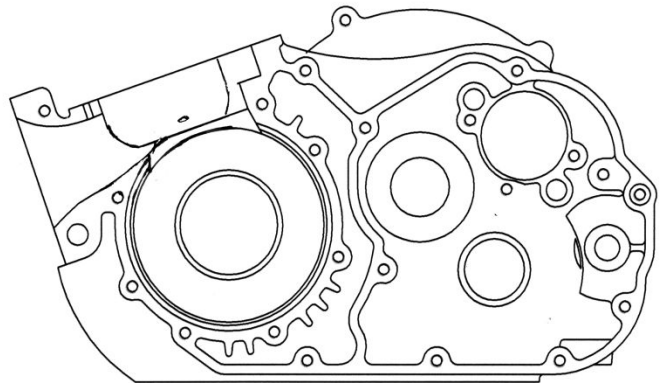
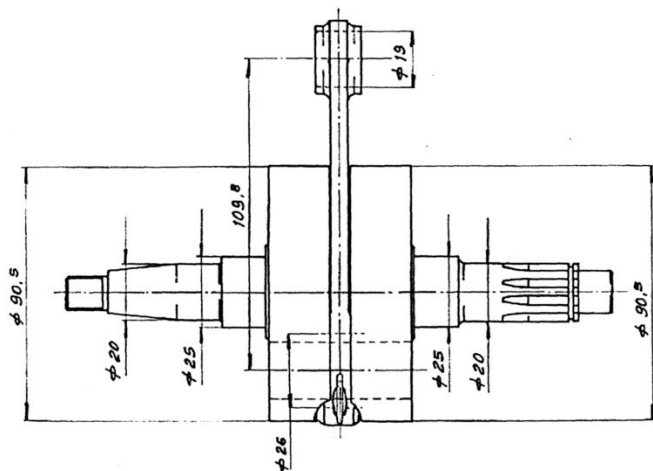



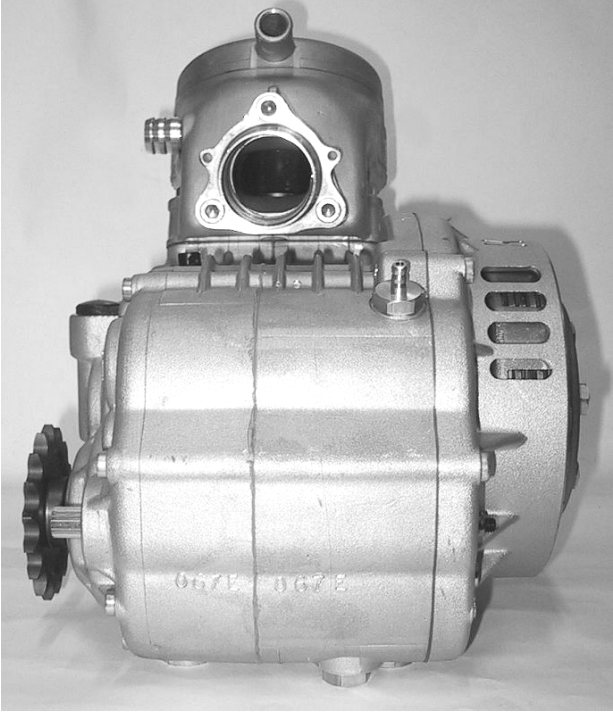
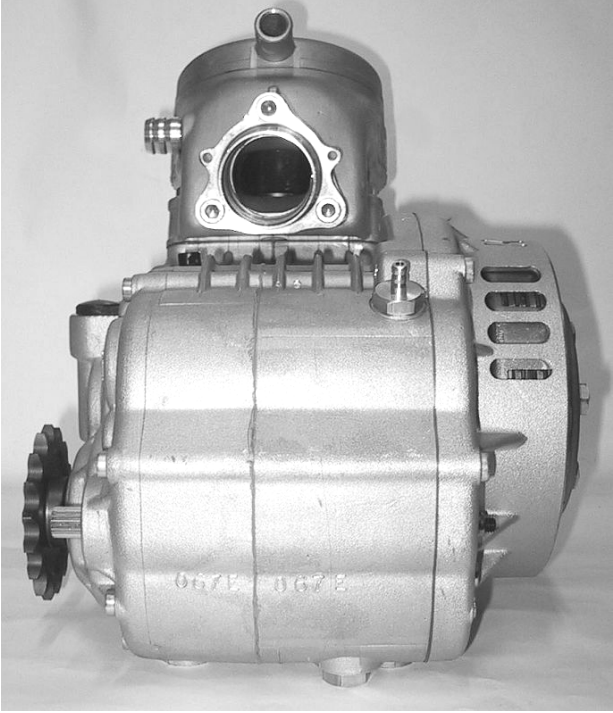
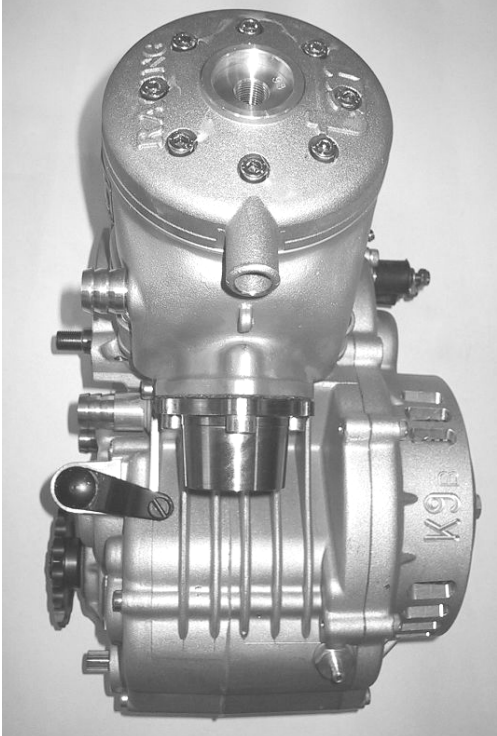
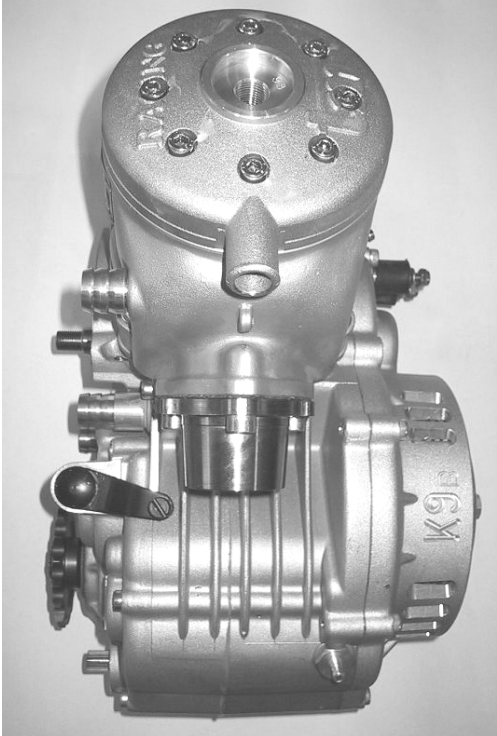
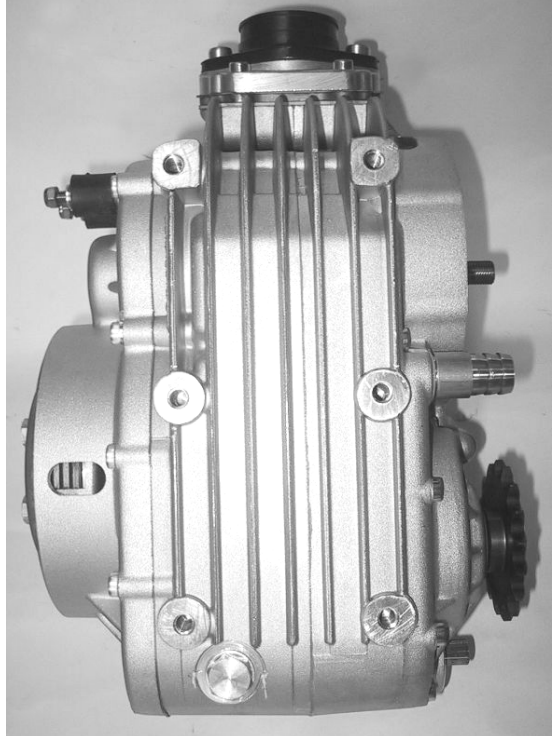
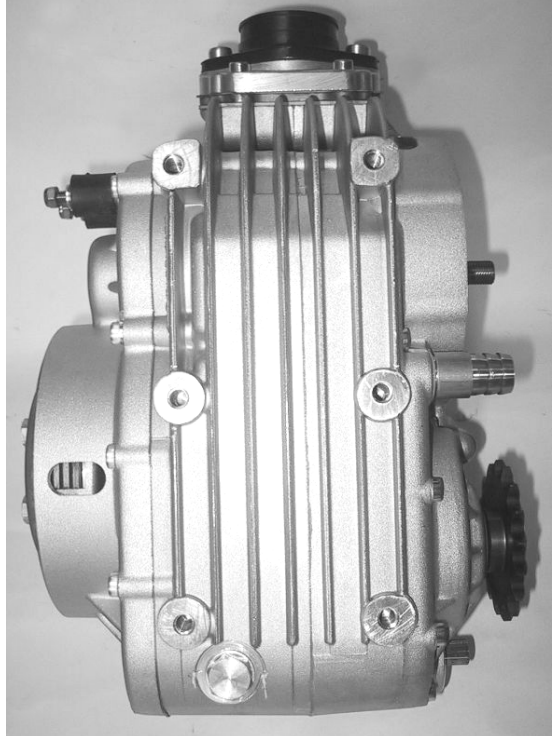

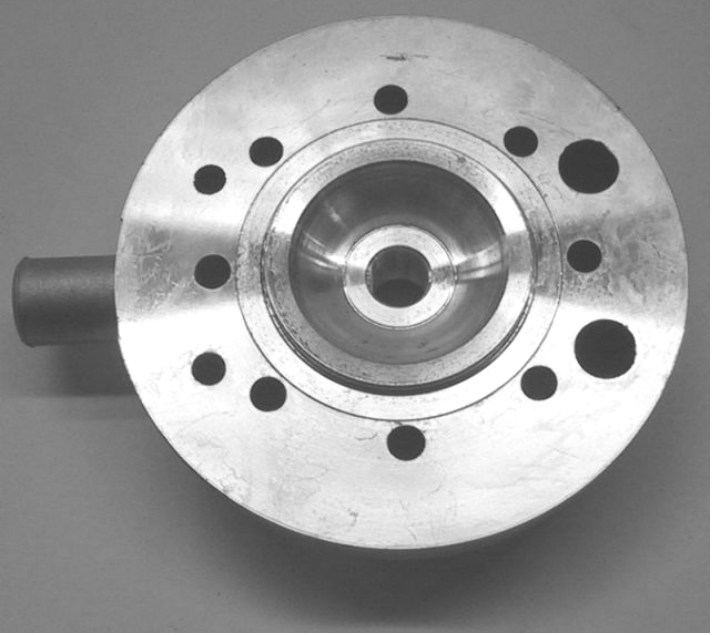
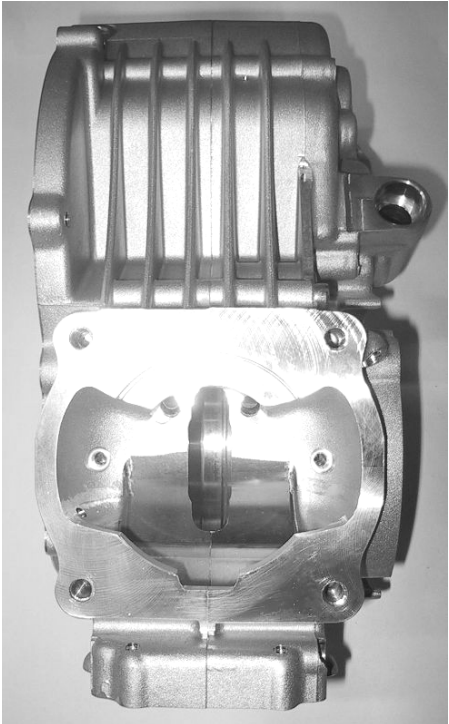

PHOTO DE L'ARRIÈRE DU MOTEUR	PHOTO OF THE BACK OF THE ENGINE	PHOTO DE L'AVANT DU MOTEUR	PHOTO OF THE FRONT OF ENGINE
			
PHOTO DU MOTEUR PARTIE SUPÉRIEURE	PHOTO OF THE ENGINE TAKEN FROM ABOVE	PHOTO DU MOTEUR PARTIE INFÉRIEURE	PHOTO OF THE ENGINE TAKEN FROM BELOW
			

PHOTO DU PIED DU CYLINDRE	PHOTO OF THE BASE OF THE CYLINDER	PHOTO DE LA CHAMBRE DE COMBUSTION	PHOTO OF COMBUSTION CHAMBER
			
PHOTO DU CARTER (CÔTÉ JOINT)	PHOTO OF THE SUMP (GASKET FACE)	PHOTO D'UNE PARTIE INTÉRIEURE DU CARTER	PHOTO OF AN INTERNAL PART OF THE SUMP
			

DESSIN DE LA BOÎTE À CLAPETS

DRAWING OF REED VALVE

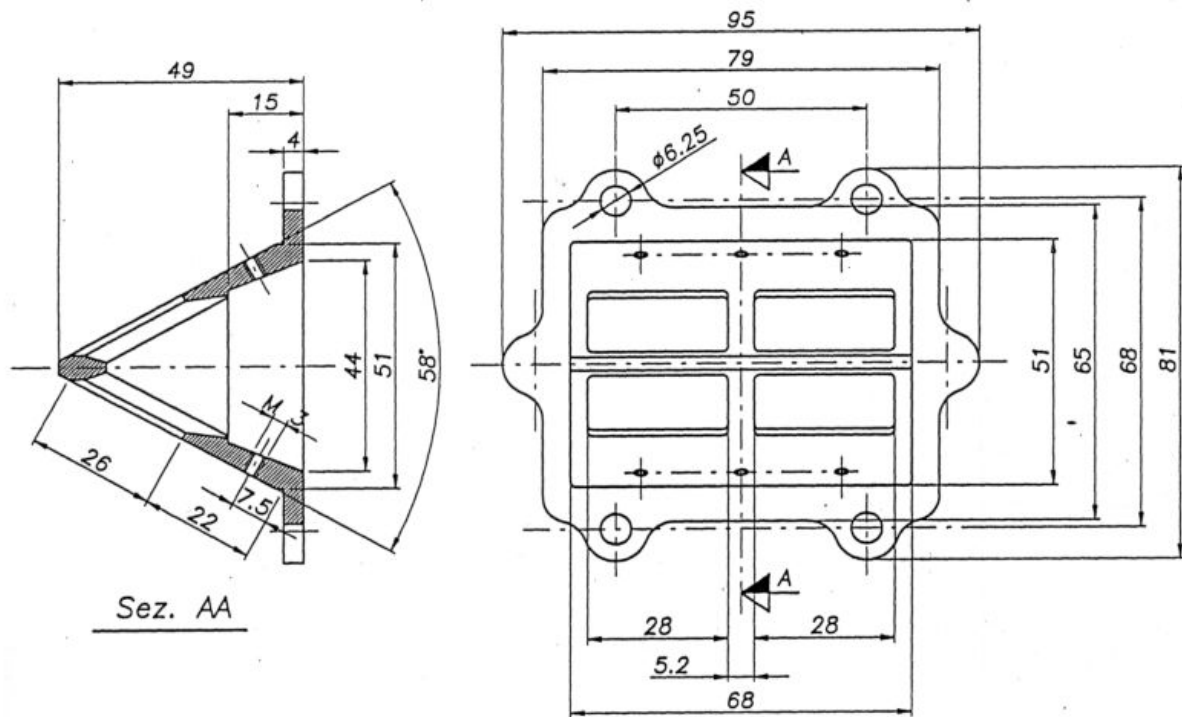

DESSIN DU COUVERCLE DE LA BOÎTE À CLAPETS

DRAWING OF REED VALVE COVER

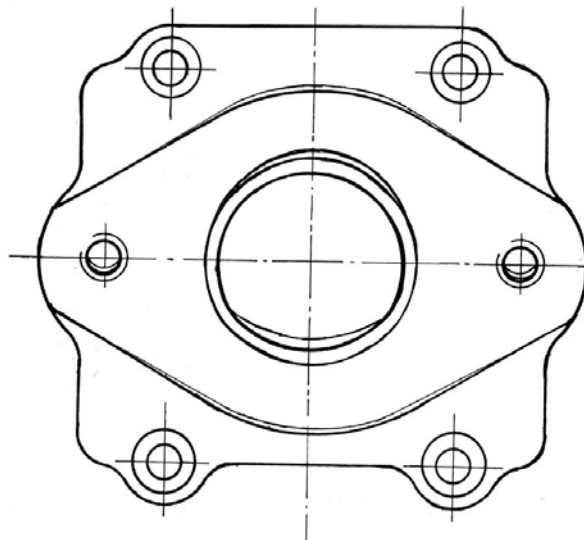

BOÎTE DE VITESSES		GEARBOX	
Couple primaire		<i>Primary coupling</i>	19/75
Rapports de boîte de vitesses		<i>Gearbox ratios</i>	
Vitesse	Arbre primaire	Arbre secondaire	Relevé des valeurs obtenues après trois tours moteur
<i>Gear</i>	<i>Primary shaft</i>	<i>Secondary shaft</i>	<i>Reading of values obtained after three engine revs</i>
1 ^{ère} /1 st	13	33	107.8°
2 ^e /2 nd	16	29	151.0°
3 ^e /3 rd	18	27	182.4°
4 ^e /4 th	22	27	222.9°
5 ^e /5 th	22	23	261.7°
6 ^e /6 th	27	25	295.5°

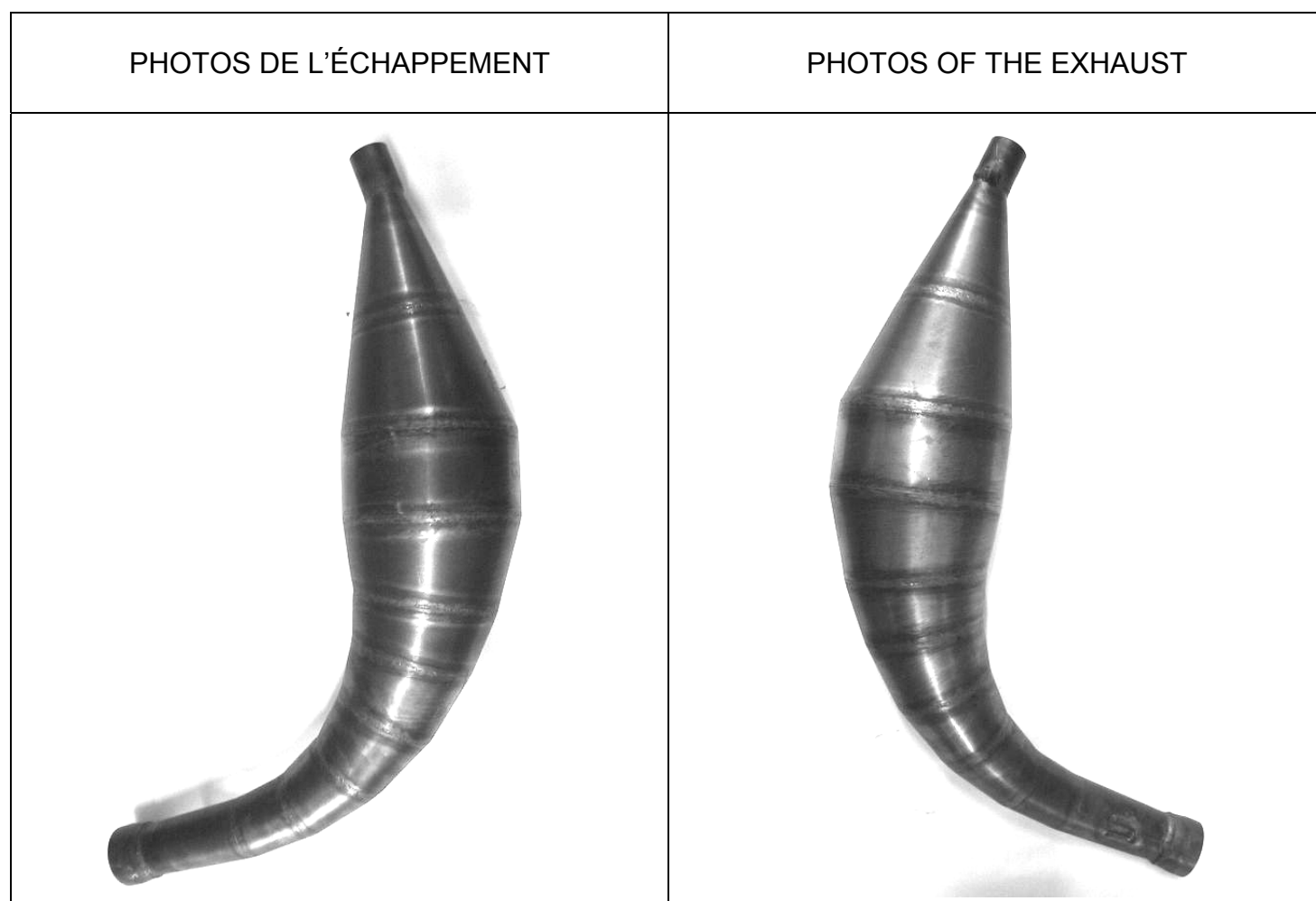

DESCRIPTIONS TECHNIQUES		TECHNICAL DESCRIPTIONS	
Poids en gr		Weight in gr	1080
Volume in cm ³		Volume in cc	3982
			Minimum
			+/-5 %

DESSINS TECHNIQUES	TECHNICAL DRAWINGS
Contenant toutes les informations permettant de construire cet échappement.	Including all the information necessary to build this exhaust.

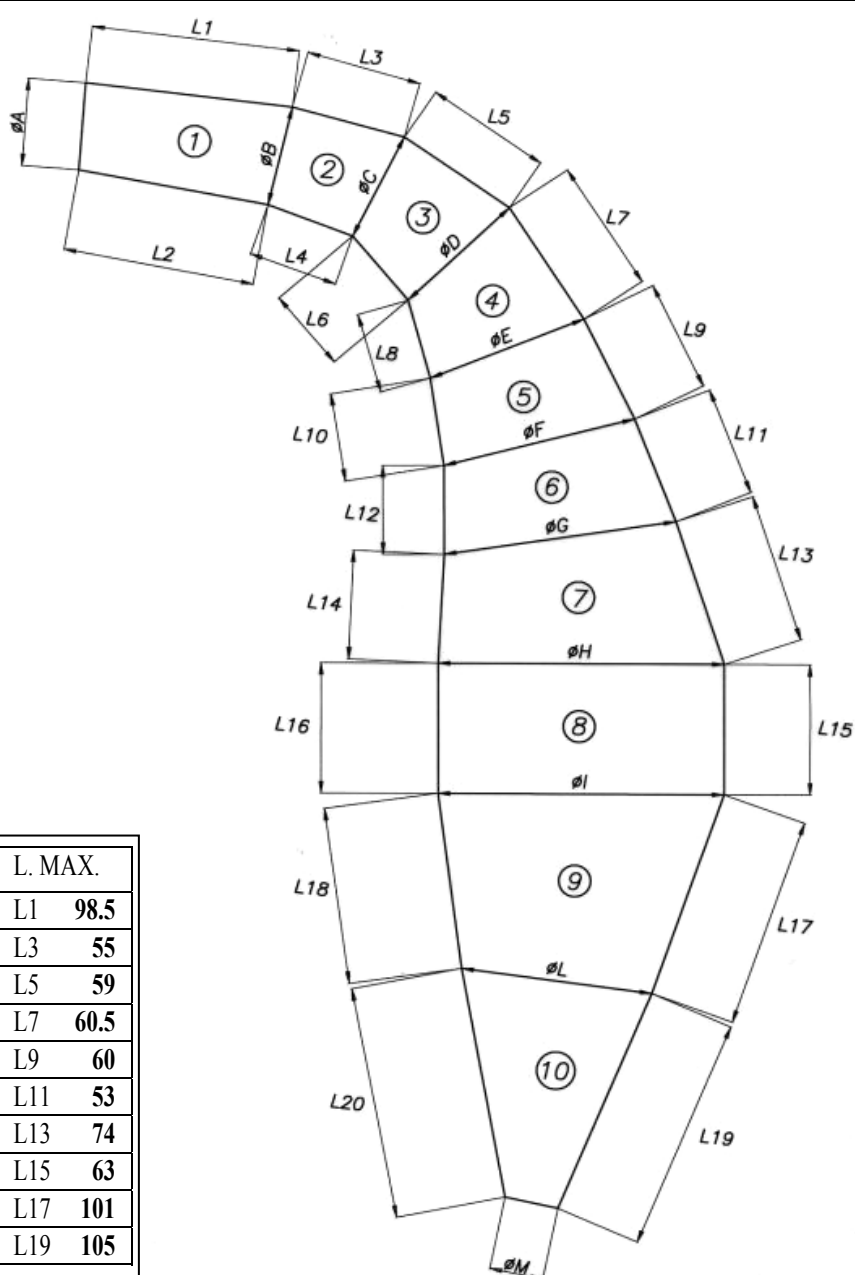

Partie/Part	D. MIN.	D. MAX	L. MIN.	L. MAX.
1	ØA 42.8	ØB 49	L2 91	L1 98.5
2	ØB 49	ØC 54	L4 43	L3 55
3	ØC 54	ØD 66	L6 44	L5 59
4	ØD 66	ØE 80	L8 42	L7 60.5
5	ØE 80	ØF 95	L10 41.3	L9 60
6	ØF 95	ØG 112	L12 38.5	L11 53
7	ØG 112	ØH 137	L14 51.5	L13 74
8	ØH 137	ØI 137	L16 63	L15 63
9	ØI 137	ØL 88	L18 83	L17 101
10	ØL 88	ØM 25.7	L20 105	L19 105